

# DATA SHEET

**TDA7052**

**1 W BTL mono audio amplifier**

Product specification  
File under Integrated Circuits, IC01

July 1994

**1 W BTL mono audio amplifier****TDA7052****GENERAL DESCRIPTION**

The TDA7052 is a mono output amplifier in a 8-lead dual-in-line (DIL) plastic package. The device is designed for battery-fed portable audio applications.

**Features:**

- No external components
- No switch-on or switch-off clicks
- Good overall stability
- Low power consumption
- No external heatsink required
- Short-circuit proof

**QUICK REFERENCE DATA**

SYMBOL	PARAMETER	CONDITIONS	MIN.	TYP.	MAX.	UNIT
$V_P$	Supply voltage range		3	6	18	V
$I_{tot}$	Total quiescent current	$R_L = \infty$	–	4	8	mA
$G_V$	Voltage gain		38	39	40	dB
$P_o$	Output power	THD = 10%; 8 $\Omega$	–	1,2	–	W
THD	Total harmonic distortion	$P_o = 0,1$ W	–	0,2	1,0	%

**PACKAGE OUTLINE**

8-lead DIL; plastic (SOT97); SOT97-1; 1996 August 21.

1 W BTL mono audio amplifier

TDA7052

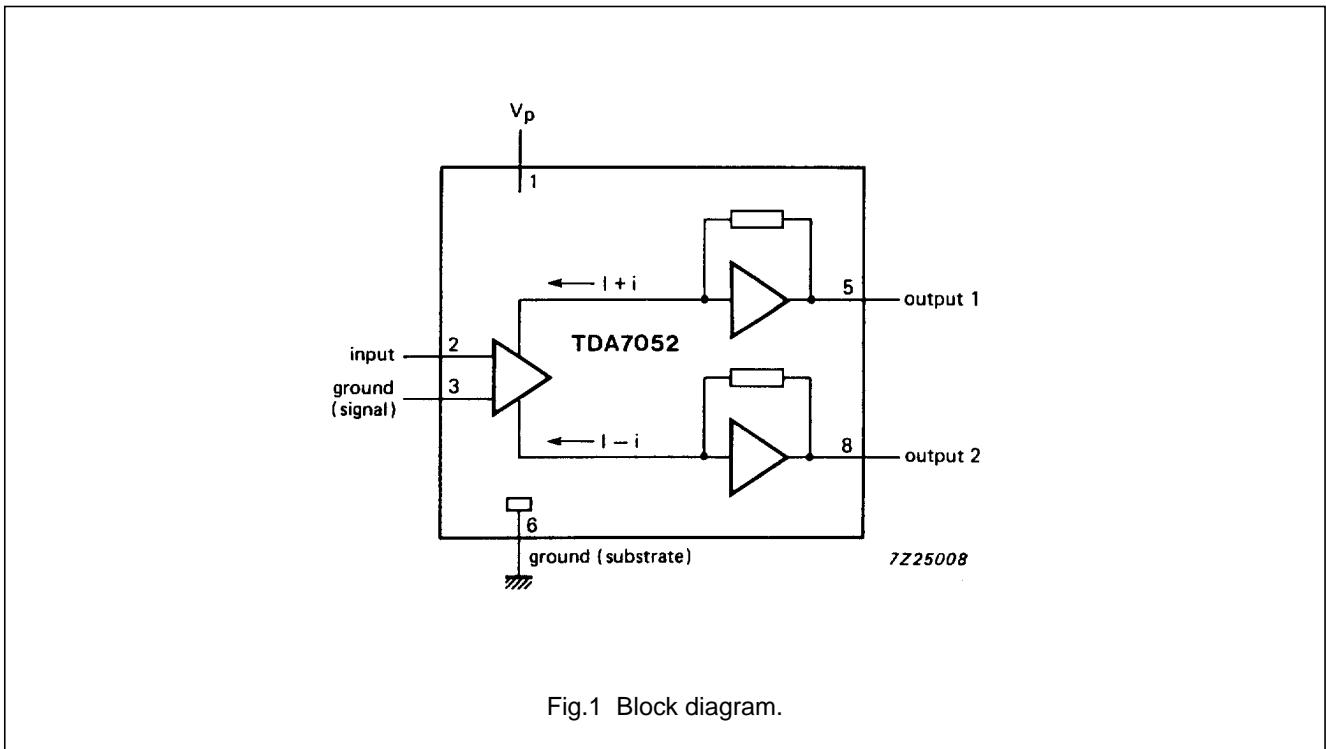

**PINNING**

1	V <sub>P</sub>	supply voltage	5	OUT1	output1
2	IN	input	6	GND2	ground (substrate)
3	GND1	ground (signal)	7	n.c.	not connected
4	n.c.	not connected	8	OUT2	output2

## 1 W BTL mono audio amplifier

TDA7052

## FUNCTIONAL DESCRIPTION

The TDA7052 is a mono output amplifier designed for battery-fed portable audio applications, such as tape recorders and radios.

The gain is fixed internally at 40 dB. A large number of tape recorders and radios are still designed for mono sound, plus a space-saving trend by reduction of the number of battery cells. This means a decrease in supply voltage which results in an reduction of output power. To compensate for this reduction, the TDA7052 uses the Bridge-Tied-Load principle (BTL) which can deliver an output power of 1,2 W (THD = 10%) into an 8  $\Omega$  load with a power supply of 6 V. The load can be short-circuited at each signal excursion.

## RATINGS

Limiting values in accordance with the Absolute Maximum System (IEC 134)

SYMBOL	PARAMETER	MIN.	MAX.	UNIT
$V_P$	Supply voltage	–	18	V
$I_{OSM}$	Non-repetitive peak output current	–	1,5	A
$P_{tot}$	Total power dissipation	see Fig. 2		
$T_c$	Crystal temperature	–	150	$^{\circ}\text{C}$
$T_{stg}$	Storage temperature range	–55	+150	$^{\circ}\text{C}$

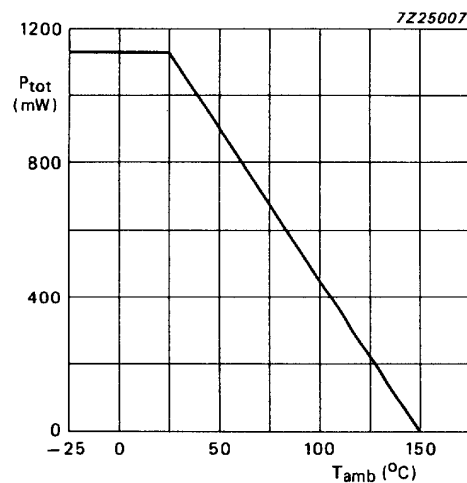

Fig.2 Power derating curve.

## POWER DISSIPATION

Assume  $V_P = 6$  V;  $R_L = 8$   $\Omega$ ;  $T_{amb} = 50$   $^{\circ}\text{C}$  maximum.

The maximum sinewave dissipation is 0,9 W.

$$R_{th\ j-a} = \frac{150 - 50}{0,9} \approx 110 \text{ K/W.}$$

Where  $R_{th\ j-a}$  of the package is 110 K/W, so no external heatsink is required.

## 1 W BTL mono audio amplifier

## TDA7052

**CHARACTERISTICS**

$V_P = 6\text{ V}$ ;  $R_L = 8\ \Omega$ ;  $f = 1\text{ kHz}$ ;  $T_{\text{amb}} = 25\text{ °C}$ ; unless otherwise specified.

SYMBOL	PARAMETER	CONDITIONS	MIN.	TYP.	MAX.	UNIT
<b>Supply</b>						
$V_P$	Supply voltage range		3	6	18	V
$I_{\text{tot}}$	Total quiescent current	$R_L = \infty$	–	4	8	mA
$G_v$	Voltage gain		38	39	40	dB
$P_o$	Output power	THD = 10%	–	1,2	–	W
	Noise output voltage (RMS value)					
$V_{\text{no(rms)}}$		note 1	–	150	300	$\mu\text{V}$
$V_{\text{no(rms)}}$		note 2	–	60	–	$\mu\text{V}$
$f_r$	Frequency response		–	20 Hz to 20 kHz	–	Hz
SVRR	Supply voltage ripple rejection	note 3	40	50	–	dB
	DC output offset voltage					
$\Delta V_{5-8}$	pin 5 to 8	$R_S = 5\text{ k}\Omega$	–	–	100	mV
THD	Total harmonic distortion	$P_O = 0,1\text{ W}$	–	0,2	1,0	%
$ Z_i $	Input impedance		–	100	–	$\text{k}\Omega$
$I_{\text{bias}}$	Input bias current		–	100	300	nA

**Notes to the characteristics**

1. The unweighted RMS noise output voltage is measured at a bandwidth of 60 Hz to 15 kHz with a source impedance ( $R_S$ ) of 5 k $\Omega$ .
2. The RMS noise output voltage is measured at a bandwidth of 5 kHz with a source impedance of 0  $\Omega$  and a frequency of 500 kHz. With a practical load ( $R = 8\ \Omega$ ;  $L = 200\ \mu\text{H}$ ) the noise output current is only 100 nA.
3. Ripple rejection is measured at the output with a source impedance of 0  $\Omega$  and a frequency between 100 Hz and 10 kHz. The ripple voltage = 200 mV (RMS value) is applied to the positive supply rail.

1 W BTL mono audio amplifier

TDA7052

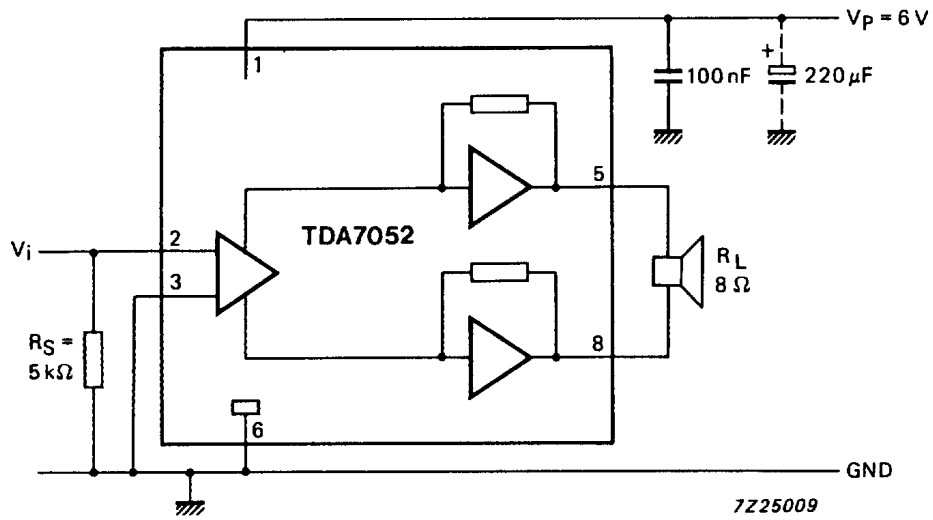

Fig.3 Application diagram.

1 W BTL mono audio amplifier

TDA7052

PACKAGE OUTLINE

DIP8: plastic dual in-line package; 8 leads (300 mil)

SOT97-1

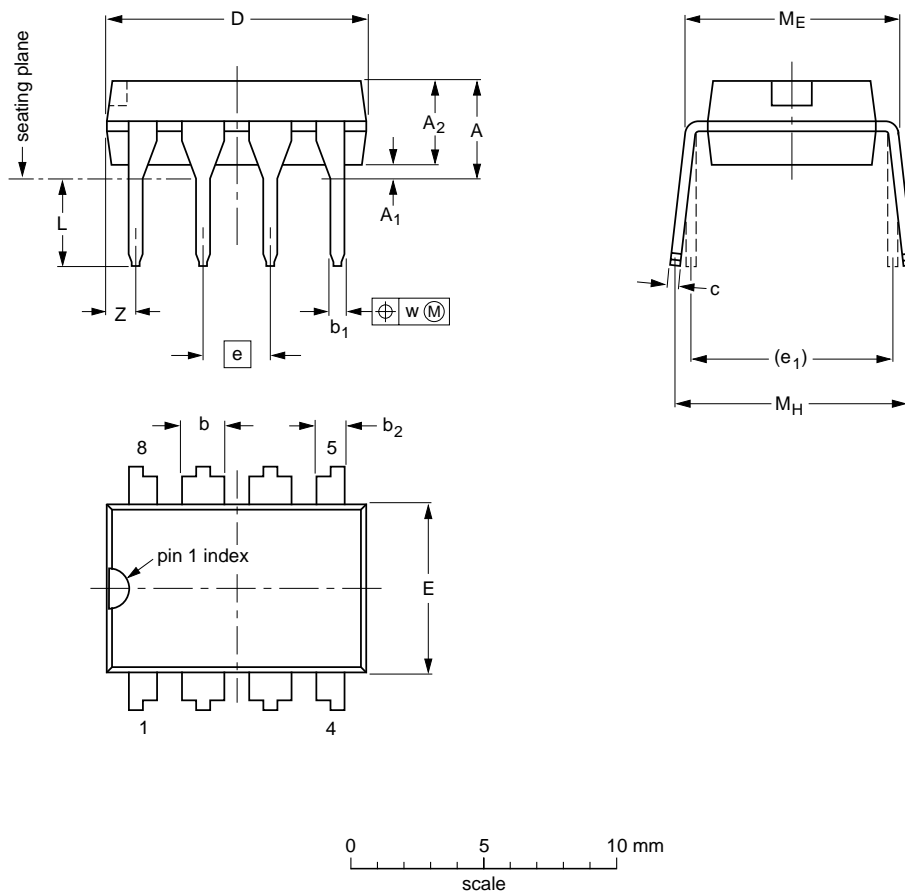

DIMENSIONS (inch dimensions are derived from the original mm dimensions)

UNIT	A max.	A <sub>1</sub> min.	A <sub>2</sub> max.	b	b <sub>1</sub>	b <sub>2</sub>	c	D <sup>(1)</sup>	E <sup>(1)</sup>	e	e <sub>1</sub>	L	M <sub>E</sub>	M <sub>H</sub>	w	Z <sup>(1)</sup> max.
mm	4.2	0.51	3.2	1.73 1.14	0.53 0.38	1.07 0.89	0.36 0.23	9.8 9.2	6.48 6.20	2.54	7.62	3.60 3.05	8.25 7.80	10.0 8.3	0.254	1.15
inches	0.17	0.020	0.13	0.068 0.045	0.021 0.015	0.042 0.035	0.014 0.009	0.39 0.36	0.26 0.24	0.10	0.30	0.14 0.12	0.32 0.31	0.39 0.33	0.01	0.045

Note

1. Plastic or metal protrusions of 0.25 mm maximum per side are not included.

OUTLINE VERSION	REFERENCES				EUROPEAN PROJECTION	ISSUE DATE
	IEC	JEDEC	EIAJ			
SOT97-1	050G01	MO-001AN				92-11-17 95-02-04

## 1 W BTL mono audio amplifier

## TDA7052

**SOLDERING****Introduction**

There is no soldering method that is ideal for all IC packages. Wave soldering is often preferred when through-hole and surface mounted components are mixed on one printed-circuit board. However, wave soldering is not always suitable for surface mounted ICs, or for printed-circuits with high population densities. In these situations reflow soldering is often used.

This text gives a very brief insight to a complex technology. A more in-depth account of soldering ICs can be found in our "IC Package Databook" (order code 9398 652 90011).

**Soldering by dipping or by wave**

The maximum permissible temperature of the solder is 260 °C; solder at this temperature must not be in contact with the joint for more than 5 seconds. The total contact time of successive solder waves must not exceed 5 seconds.

The device may be mounted up to the seating plane, but the temperature of the plastic body must not exceed the specified maximum storage temperature ( $T_{stg\ max}$ ). If the printed-circuit board has been pre-heated, forced cooling may be necessary immediately after soldering to keep the temperature within the permissible limit.

**Repairing soldered joints**

Apply a low voltage soldering iron (less than 24 V) to the lead(s) of the package, below the seating plane or not more than 2 mm above it. If the temperature of the soldering iron bit is less than 300 °C it may remain in contact for up to 10 seconds. If the bit temperature is between 300 and 400 °C, contact may be up to 5 seconds.

**DEFINITIONS**

<b>Data sheet status</b>	
Objective specification	This data sheet contains target or goal specifications for product development.
Preliminary specification	This data sheet contains preliminary data; supplementary data may be published later.
Product specification	This data sheet contains final product specifications.
<b>Limiting values</b>	
Limiting values given are in accordance with the Absolute Maximum Rating System (IEC 134). Stress above one or more of the limiting values may cause permanent damage to the device. These are stress ratings only and operation of the device at these or at any other conditions above those given in the Characteristics sections of the specification is not implied. Exposure to limiting values for extended periods may affect device reliability.	
<b>Application information</b>	
Where application information is given, it is advisory and does not form part of the specification.	

**LIFE SUPPORT APPLICATIONS**

These products are not designed for use in life support appliances, devices, or systems where malfunction of these products can reasonably be expected to result in personal injury. Philips customers using or selling these products for use in such applications do so at their own risk and agree to fully indemnify Philips for any damages resulting from such improper use or sale.



Copyright © Each Manufacturing Company.

All Datasheets cannot be modified without permission.

This datasheet has been download from :

[www.AllDataSheet.com](http://www.AllDataSheet.com)

100% Free DataSheet Search Site.

Free Download.

No Register.

Fast Search System.

[www.AllDataSheet.com](http://www.AllDataSheet.com)